

| ECOWARN

ALARM CONTROL UNIT
FOR OIL/WATER SEPARATORS

PRODUCT OVERVIEW

ECOWARN

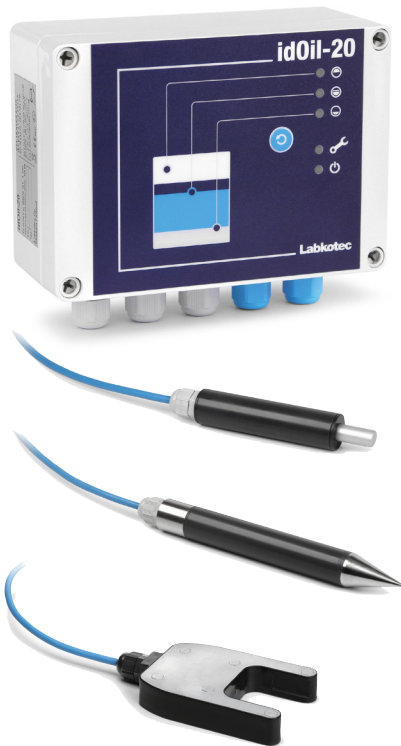

EcoWarn is a combined control device for oil/water separators to monitor the level of separated oil as well as to signalize a high liquid level inside the separation chamber.

The measuring circle is Ex-proof, tested according to the European Standard EN61010-1.

EcoWarn is optimally designed to be used in combination with our oil/water separators.

Specification:

- 100-240 VAC, 50/60 Hz
- Sensor combination with up to three different sensors.
- Polarity-free sensor connection.
- Control unit with visual and acoustic alarm, to be wall mounted
- 2 potential free relay outlets
- incl. mounting material

Available sensors:

- **High Liquid Level Sensor:** Indicates when the liquid level in the oil/water separator rises excessively.
- **Oil Sensor:** Detects oil and indicates when the separator's oil storage is full.
- **Sludge Sensor:** Monitors the sludge layer in the oil/water separator and indicates when the sludge layer has reached its maximum level.

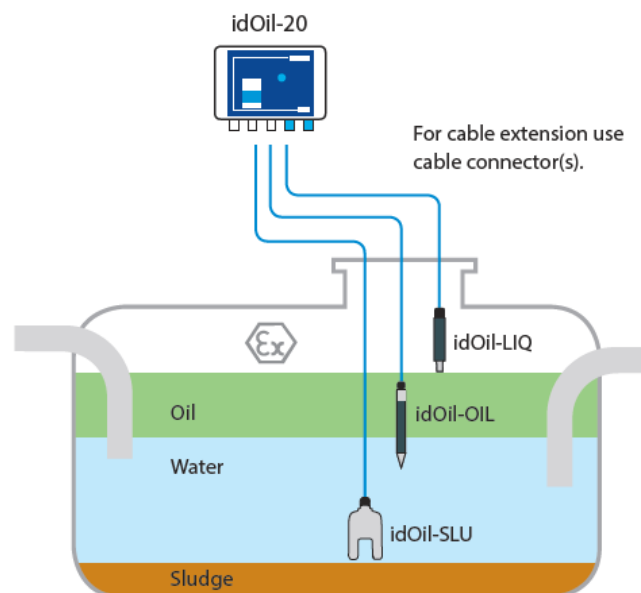



SCHLÜSSELBAUER 
ECOTECHNIC

Illustrations may differ from the original.
Version 07/2022: Subject to errors, technical changes and typographical errors.

SCHLÜSSELBAUER Ecotechnic GmbH & Co KG
A-4673 Gaspoltshofen, Hörbach 4
Tel. +43 7735 7320-0
support@ecotechnic.at | ecotechnic.at